

THE PROPERTY OF THE DRAWING IS ESTABLISHED BY LAW. IT IS FORBIDDEN TO PRODUCE OR SHOW IT TO THIRD PARTY, WITHOUT A WRITTEN AGREEMENT.

Item	Name	Q.ty
1	APG.25.14.40	1
2	R.3.SCH	2
3	V.TCE3x12	2

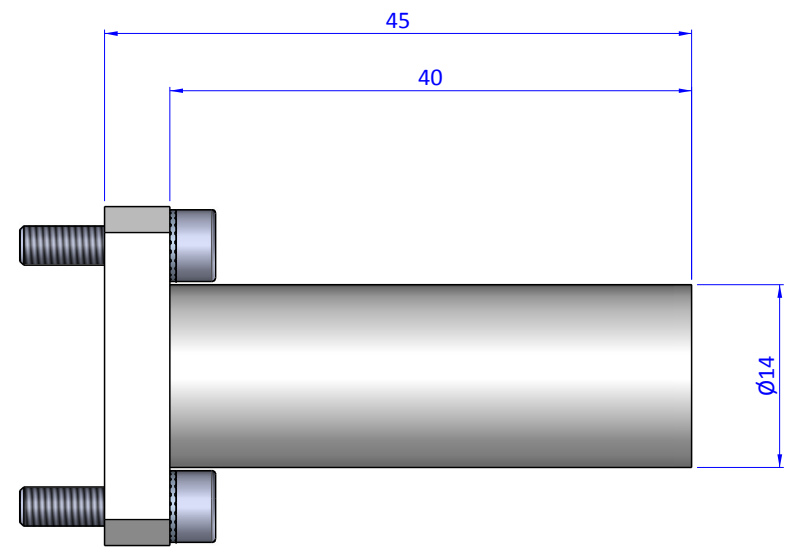
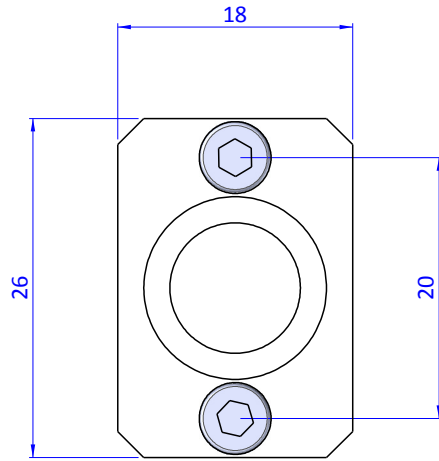
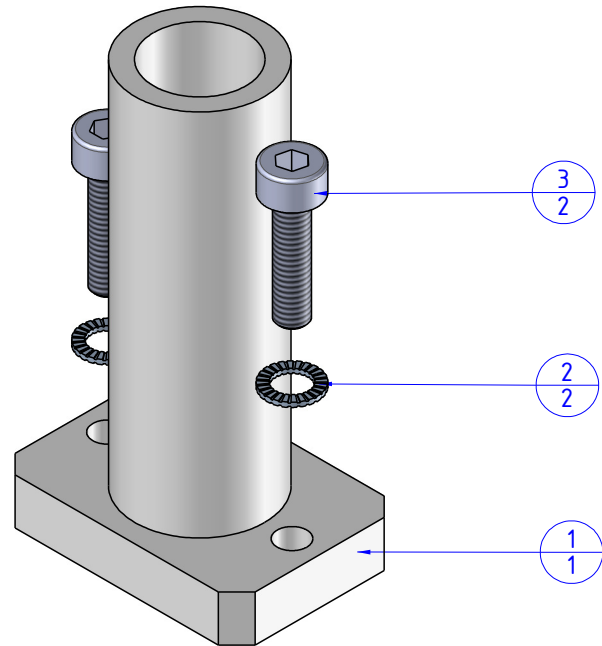

Format A3

UNI 936-76

		DESIGNED FROM		REVIEW
		FPS Automation		A
GENERAL TOLERANCE UNI - ISO 2768 CLASSE f		DATE	WEIGHT	
		30/05/2019	0,013kg	
DESCRIPTION		CODE		
CA.APG.25.14.40		CA.APG.25.14.40		